

ACOUSTO-OPTIC Q SWITCH — GSU-5

This is a water-cooled acousto-optic Q switch mainly used in Nd:YAG laser system. The melted quartz blocks with very good optical feature and films with high penetrability are used, which optical character is very good. The cavity insertion loss is low and the anti-injury threshold is high.

Specifications

Working Wavelength	1047-1064nm
Anti-reflection Film	<0.2% Every Surface
Working Frequency	27MHz or 40MHz
Standing Wave Ratio	<1.2:1
Output Electronic Power	50W
Clear Aperture	Φ 3mm or Φ 4mm
Highest Water Temperature	+40°C
Water Adapter	Extraction-insertion
Protection Temperature	+55°C ± 5°C

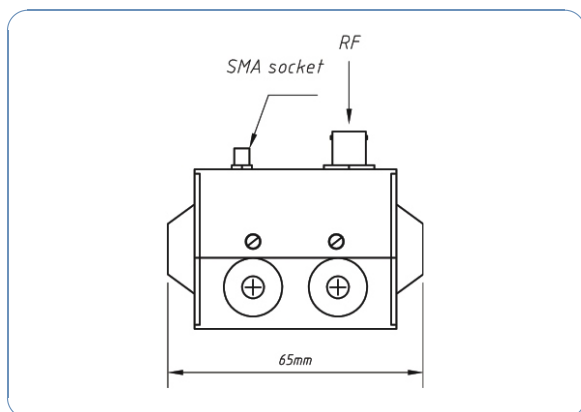
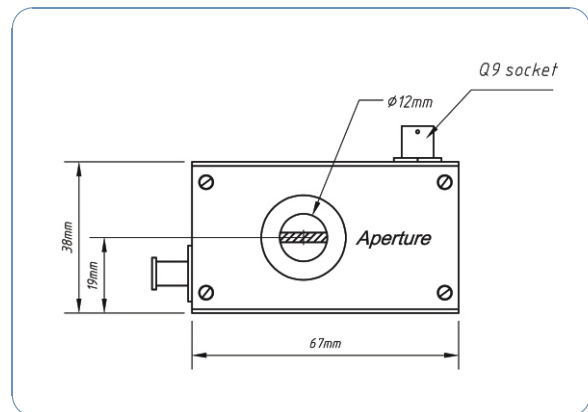
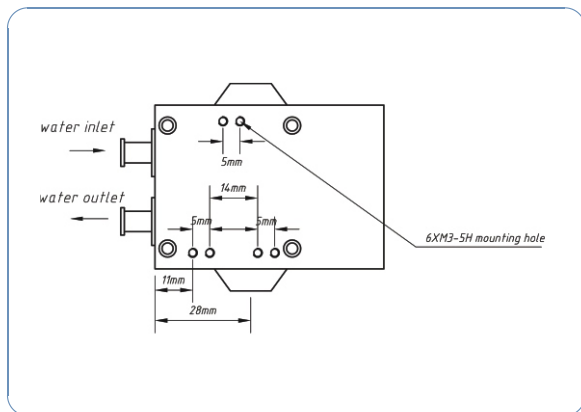

ACOUSTO-OPTIC Q SWITCH — GSU-6

The Q switch is consisted of the device and the power supply and always uses in diode pumping solid-state laser for Q modulating. No water-cooling is needed. The responding speed is fast and easy to control. Small size and good stability make it suitable to be used in the diode pumping solid-state laser.

Specifications

Interactive Material	Special Glass
Working Frequency	Single Wavelength 1.06 μ m
Carrier Wave Frequency	40MHz or 70MHz
Diffraction Ratio	40%-70%
Electronic Power	2.5W-5W
Pulse Rise Time	$\leq 10\text{ns}@70\text{MHz}$ or $\leq 25\text{ns}@40\text{MHz}$
Modulating Frequency	1 KHz-50 KHz
Anti-Reflection Film	<2% Each Surface
Anti-injury Threshold	500mW/cm ²
VSWR	<1.2:1
Clear Aperture	1mm

